







**Catégorie**
**Lisse Star**

Category – Kategorie – Categoria – Categoría

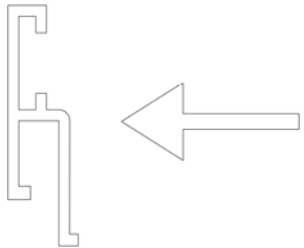
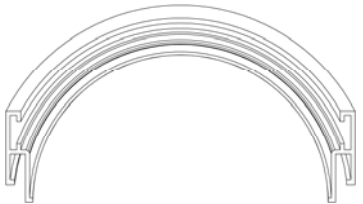
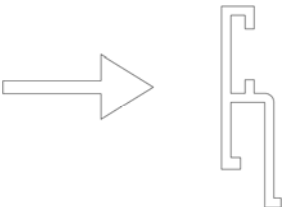
**Référence**
**BSC 350/01**

Reference – Referenz – Seferencia – Riferimento



|          | <b>DENOMINATION</b><br>DESCRIPTION<br>BESCHREIBUNG<br>DESCRIPCION<br>DESCRIZIONE                      | <b>SENS</b><br>DIRECTION OF RADII<br>RICHTUNG - SENTIDO - SENSO                     | <b>SCHEMA</b><br>VIEW - ZEICHNUNG - ESQUEMA<br>SCHEMA                                | <b>R MINI (mm)</b><br>MINIMUM RADIUS<br>MINIMALER RADIUS<br>RADIO MINIMO<br>RAGGIO MINIMO |
|----------|-------------------------------------------------------------------------------------------------------|-------------------------------------------------------------------------------------|--------------------------------------------------------------------------------------|-------------------------------------------------------------------------------------------|
| <b>A</b> | <b>Plat concave</b><br>Concave vertical plane<br>Konkav Rundung<br>Plano concavo<br>Piano concavo     |    |    | 250                                                                                       |
| <b>B</b> | <b>Plat convexe</b><br>Convex vertical plane<br>Konvex Rundung<br>Plano convexo<br>Piano convesso     |   |   | 250                                                                                       |
| <b>C</b> | <b>Chant concave</b><br>Concave horizontal plane<br>Konkav Rundung<br>Canto concavo<br>Taglio concavo |  |  | 500                                                                                       |
| <b>D</b> | <b>Chant convexe</b><br>Convex horizontal plane<br>Konkav Rundung<br>Canto convexo<br>Taglio convesso |  |  | 300                                                                                       |

**N° CLIENT :**

Customer – Kunde – Cliente – Cliente

**COMMANDE du** / /

Order of – Bestellung Datum – Pedido del – Ordine del

| <b>CINTRAGE</b><br>BENDING – BIEGUNGS – CURVATURA – CALANDRATURA                                                        | <b>A</b> | <b>B</b> | <b>C</b> | <b>D</b> |
|-------------------------------------------------------------------------------------------------------------------------|----------|----------|----------|----------|
| <b>QUANTITE</b><br>QUANTITY – MENGE – CANTIDAD – QUANTITA                                                               |          |          |          |          |
| <b>RAYON (mm)</b><br>RADIUS – RADIUS – RADIO – RAGGIO                                                                   |          |          |          |          |
| <b>LONGUEUR DEVELOPPE (mm)</b><br>DEVELOPPED LENGHT – ENTWICKELTE LÄNGE – DESARROLLO DE LA CURVA – LUNGHEZZA SVILUPPATA |          |          |          |          |

Catégorie **Lisse Star**

Category – Kategorie – Categoria – Categoria

Référence **BSC 350/11**

Reference – Referenz – Seferencia – Riferimento



|          | DENOMINATION<br>DESCRIPTION<br>BESCHREIBUNG<br>DESCRIPCION<br>DESCRIZIONE                             | SENS<br>DIRECTION OF RADII<br>RICHTUNG - SENTIDO - SENSO | SCHEMA<br>VIEW - ZEICHNUNG - ESQUEMA<br>SCHEMA | R MINI (mm)<br>MINIMUM RADIUS<br>MINIMALER RADIUS<br>RADIO MINIMO<br>RAGGIO MINIMO |
|----------|-------------------------------------------------------------------------------------------------------|----------------------------------------------------------|------------------------------------------------|------------------------------------------------------------------------------------|
| <b>A</b> | <b>Plat concave</b><br>Concave vertical plane<br>Konkav Rundung<br>Plano concavo<br>Piano concavo     |                                                          |                                                | 500                                                                                |
| <b>B</b> | <b>Plat convexe</b><br>Convex vertical plane<br>Konvex Rundung<br>Plano convexo<br>Piano convesso     |                                                          |                                                | 600                                                                                |
| <b>C</b> | <b>Chant concave</b><br>Concave horizontal plane<br>Konkav Rundung<br>Canto concavo<br>Taglio concavo |                                                          |                                                | 300                                                                                |
| <b>D</b> | <b>Chant convexe</b><br>Convex horizontal plane<br>Konkav Rundung<br>Canto convexo<br>Taglio convesso |                                                          |                                                | 300                                                                                |

**N° CLIENT :**  
Customer – Kunde – Cliente – Cliente

**COMMANDE du / /**  
Order of – Bestellung Datum – Pedido del – Ordine del

| CINTRAGE<br>BENDING – BIEGUNGS – CURVATURA – CALANDRATURA                                                        | A | B | C | D |
|------------------------------------------------------------------------------------------------------------------|---|---|---|---|
| QUANTITE<br>QUANTITY – MENGE – CANTIDAD – QUANTITA                                                               |   |   |   |   |
| RAYON (mm)<br>RADIUS – RADIUS – RADIO – RAGGIO                                                                   |   |   |   |   |
| LONGUEUR DEVELOPPE (mm)<br>DEVELOPPED LENGHT – ENTWICKELTE LÄNGE – DESARROLLO DE LA CURVA – LUNGHEZZA SVILUPPATA |   |   |   |   |







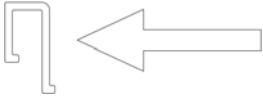

Catégorie **Lisse Star**

Category – Kategorie – Categoria – Categoria

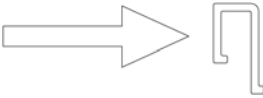
 Référence **Barridalle BDC 310/01**

Reference – Referenz – Seferencia – Riferimento



|          | <b>DENOMINATION</b><br>DESCRIPTION<br>BESCHREIBUNG<br>DESCRIPCION<br>DESCRIZIONE                      | <b>SENS</b><br>DIRECTION OF RADII<br>RICHTUNG - SENTIDO - SENSO                     | <b>SCHEMA</b><br>VIEW - ZEICHNUNG - ESQUEMA<br>SCHEMA                                | <b>R MINI (mm)</b><br>MINIMUM RADIUS<br>MINIMALER RADIUS<br>RADIO MINIMO<br>RAGGIO MINIMO |
|----------|-------------------------------------------------------------------------------------------------------|-------------------------------------------------------------------------------------|--------------------------------------------------------------------------------------|-------------------------------------------------------------------------------------------|
| <b>A</b> | <b>Plat concave</b><br>Concave vertical plane<br>Konkav Rundung<br>Plano concavo<br>Piano concavo     |    |    | 500                                                                                       |
| <b>B</b> | <b>Plat convexe</b><br>Convex vertical plane<br>Konvex Rundung<br>Plano convexo<br>Piano convesso     |  |   | 450                                                                                       |
| <b>C</b> | <b>Chant concave</b><br>Concave horizontal plane<br>Konkav Rundung<br>Canto concavo<br>Taglio concavo |  |  | 200                                                                                       |
| <b>D</b> | <b>Chant convexe</b><br>Convex horizontal plane<br>Konkav Rundung<br>Canto convexo<br>Taglio convesso |  |  | 200                                                                                       |

**N° CLIENT :**  
 Customer – Kunde – Cliente – Cliente

**COMMANDE du** / /  
 Order of – Bestellung Datum – Pedido del – Ordine del

| <b>CINTRAGE</b><br>BENDING – BIEGUNGS – CURVATURA – CALANDRATURA                                                        | <b>A</b> | <b>B</b> | <b>C</b> | <b>D</b> |
|-------------------------------------------------------------------------------------------------------------------------|----------|----------|----------|----------|
| <b>QUANTITE</b><br>QUANTITY – MENGE – CANTIDAD – QUANTITA                                                               |          |          |          |          |
| <b>RAYON (mm)</b><br>RADIUS – RADIUS – RADIO – RAGGIO                                                                   |          |          |          |          |
| <b>LONGUEUR DEVELOPPE (mm)</b><br>DEVELOPPED LENGHT – ENTWICKELTE LÄNGE – DESARROLLO DE LA CURVA – LUNGHEZZA SVILUPPATA |          |          |          |          |



|          | DENOMINATION<br>DESCRIPTION<br>BESCHREIBUNG<br>DESCRIPCION<br>DESCRIZIONE                             | SENS<br>DIRECTION OF RADII<br>RICHTUNG - SENTIDO - SENSO | SCHEMA<br>VIEW - ZEICHNUNG - ESQUEMA<br>SCHEMA | R MINI (mm)<br>MINIMUM RADIUS<br>MINIMALER RADIUS<br>RADIO MINIMO<br>RAGGIO MINIMO |
|----------|-------------------------------------------------------------------------------------------------------|----------------------------------------------------------|------------------------------------------------|------------------------------------------------------------------------------------|
| <b>A</b> | <b>Plat concave</b><br>Concave vertical plane<br>Konkav Rundung<br>Plano concavo<br>Piano concavo     |                                                          |                                                | 280                                                                                |
| <b>B</b> | <b>Plat convexe</b><br>Convex vertical plane<br>Konvex Rundung<br>Plano convexo<br>Piano convesso     |                                                          |                                                | 230                                                                                |
| <b>C</b> | <b>Chant concave</b><br>Concave horizontal plane<br>Konkav Rundung<br>Canto concavo<br>Taglio concavo |                                                          |                                                | <b>Non cintrable<br/>Unbendable</b><br><br><b>X</b>                                |

**N° CLIENT :**





Customer – Kunde – Cliente – Cliente

**COMMANDE du / /**

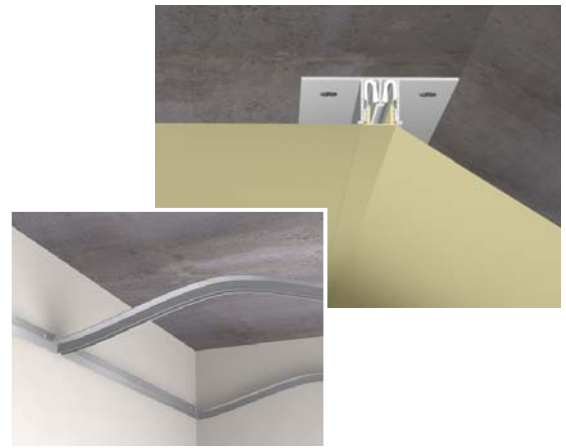
Order of – Bestellung Datum – Pedido del – Ordine del

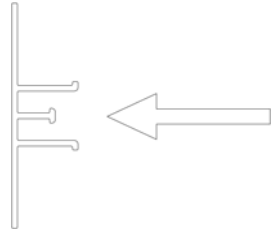
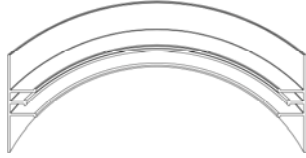
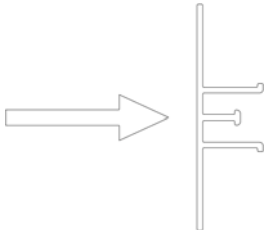
| CINTRAGE<br>BENDING – BIEGUNGS – CURVATURA – CALANDRATURA                                                        | A | B | C | D |
|------------------------------------------------------------------------------------------------------------------|---|---|---|---|
| QUANTITE<br>QUANTITY – MENGE – CANTIDAD – QUANTITA                                                               |   |   |   |   |
| RAYON (mm)<br>RADIUS – RADIUS – RADIO – RAGGIO                                                                   |   |   |   |   |
| LONGUEUR DEVELOPPE (mm)<br>DEVELOPPED LENGHT – ENTWICKELTE LÄNGE – DESARROLLO DE LA CURVA – LUNGHEZZA SVILUPPATA |   |   |   |   |



|          | DENOMINATION<br>DESCRIPTION<br>BESCHREIBUNG<br>DESCRIPCION<br>DESCRIZIONE                             | SENS<br>DIRECTION OF RADII<br>RICHTUNG - SENTIDO - SENSO                            | SCHEMA<br>VIEW - ZEICHNUNG - ESQUEMA<br>SCHEMA                                       | R MINI (mm)<br>MINIMUM RADIUS<br>MINIMALER RADIUS<br>RADIO MINIMO<br>RAGGIO MINIMO |
|----------|-------------------------------------------------------------------------------------------------------|-------------------------------------------------------------------------------------|--------------------------------------------------------------------------------------|------------------------------------------------------------------------------------|
| <b>A</b> | <b>Plat concave</b><br>Concave vertical plane<br>Konkav Rundung<br>Plano concavo<br>Piano concavo     |    |    | 250                                                                                |
| <b>B</b> | <b>Plat convexe</b><br>Convex vertical plane<br>Konvex Rundung<br>Plano convexo<br>Piano convesso     |   |  | 250                                                                                |
| <b>C</b> | <b>Chant concave</b><br>Concave horizontal plane<br>Konkav Rundung<br>Canto concavo<br>Taglio concavo |  |  | <b>Non cintrable<br/>Unbendable</b><br><br><b>X</b>                                |

N° CLIENT :







Customer – Kunde – Cliente – Cliente

COMMANDE du / /

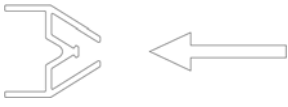
Order of – Bestellung Datum – Pedido del – Ordine del

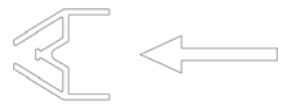
| CINTRAGE<br>BENDING – BIEGUNGS – CURVATURA – CALANDRATURA                                                        | A | B | C | D |
|------------------------------------------------------------------------------------------------------------------|---|---|---|---|
| QUANTITE<br>QUANTITY – MENGE – CANTIDAD – QUANTITA                                                               |   |   |   |   |
| RAYON (mm)<br>RADIUS – RADIUS – RADIO – RAGGIO                                                                   |   |   |   |   |
| LONGUEUR DEVELOPPE (mm)<br>DEVELOPPED LENGHT – ENTWICKELTE LÄNGE – DESARROLLO DE LA CURVA – LUNGHEZZA SVILUPPATA |   |   |   |   |

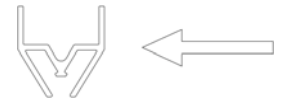





|          | DENOMINATION<br>DESCRIPTION<br>BESCHREIBUNG<br>DESCRIPCION<br>DESCRIZIONE                             | SENS<br>DIRECTION OF RADII<br>RICHTUNG - SENTIDO - SENSO                            | SCHEMA<br>VIEW - ZEICHNUNG - ESQUEMA<br>SCHEMA                                       | R MINI (mm)<br>MINIMUM RADIUS<br>MINIMALER RADIUS<br>RADIO MINIMO<br>RAGGIO MINIMO |
|----------|-------------------------------------------------------------------------------------------------------|-------------------------------------------------------------------------------------|--------------------------------------------------------------------------------------|------------------------------------------------------------------------------------|
| <b>A</b> | <b>Plat concave</b><br>Concave vertical plane<br>Konkav Rundung<br>Plano concavo<br>Piano concavo     |    |    | 200                                                                                |
| <b>B</b> | <b>Plat convexe</b><br>Convex vertical plane<br>Konvex Rundung<br>Plano convexo<br>Piano convesso     |  |  | 250                                                                                |
| <b>C</b> | <b>Chant concave</b><br>Concave horizontal plane<br>Konkav Rundung<br>Canto concavo<br>Taglio concavo |  |  | <b>Non cintrable</b><br><b>Unbendable</b><br><br><b>X</b>                          |

**N° CLIENT :**  
Customer – Kunde – Cliente – Cliente

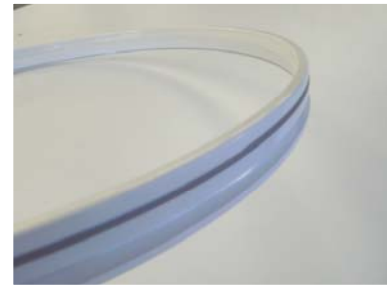
**COMMANDE du** / /  
Order of – Bestellung Datum – Pedido del – Ordine del

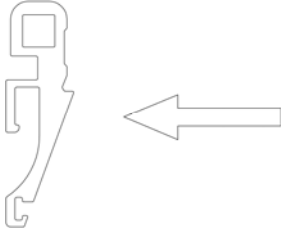
| CINTRAGE<br>BENDING – BIEGUNGS – CURVATURA – CALANDRATURA                                                        | A | B | C | D |
|------------------------------------------------------------------------------------------------------------------|---|---|---|---|
| QUANTITE<br>QUANTITY – MENGE – CANTIDAD – QUANTITA                                                               |   |   |   |   |
| RAYON (mm)<br>RADIUS – RADIUS – RADIO – RAGGIO                                                                   |   |   |   |   |
| LONGUEUR DEVELOPPE (mm)<br>DEVELOPPED LENGHT – ENTWICKELTE LÄNGE – DESARROLLO DE LA CURVA – LUNGHEZZA SVILUPPATA |   |   |   |   |

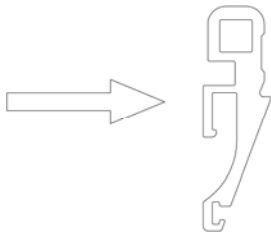
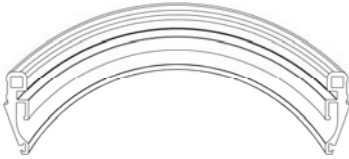

| RÉFÉRENCES<br>REFERENCE<br>REFERENZ<br>SEFERENCIA<br>RIFERIMENTO | DENOMINATION<br>DESCRIPTION<br>BESCHREIBUNG<br>DESCRIPCION<br>DESCRIZIONE                             | SENS<br>DIRECTION OF RADII<br>RICHTUNG - SENTIDO - SENSO                            | SCHEMA<br>VIEW - ZEICHNUNG - ESQUEMA<br>SCHEMA                                       | R MINI (mm)<br>MINIMUM RADIUS<br>MINIMALER RADIUS<br>RADIO MINIMO<br>RAGGIO MINIMO |
|------------------------------------------------------------------|-------------------------------------------------------------------------------------------------------|-------------------------------------------------------------------------------------|--------------------------------------------------------------------------------------|------------------------------------------------------------------------------------|
| <b>BSC<br/>355/05A</b>                                           | <b>Plat concave</b><br>Concave vertical plane<br>Konkav Rundung<br>Plano concavo<br>Piano concavo     |   |    | 300                                                                                |
| <b>BSC<br/>355/05B</b>                                           | <b>Plat convexe</b><br>Convex vertical plane<br>Konvex Rundung<br>Plano convexo<br>Piano convesso     |  |  | 200                                                                                |
| <b>BSC<br/>355/05C</b>                                           | <b>Chant concave</b><br>Concave horizontal plane<br>Konkav Rundung<br>Canto concavo<br>Taglio concavo |  |  | <b>Non cintrable<br/>Unbendable</b><br><br><b>X</b>                                |

N° CLIENT :

Customer – Kunde – Cliente – Cliente

COMMANDE du / /

Order of – Bestellung Datum – Pedido del – Ordine del

| CINTRAGE<br>BENDING – BIEGUNGS – CURVATURA – CALANDRATURA                                                           | A | B | C | D |
|---------------------------------------------------------------------------------------------------------------------|---|---|---|---|
| QUANTITE<br>QUANTITY – MENGE – CANTIDAD – QUANTITA                                                                  |   |   |   |   |
| RAYON (mm)<br>RADIUS – RADIUS – RADIO – RAGGIO                                                                      |   |   |   |   |
| LONGUEUR DEVELOPPE (mm)<br>DEVELOPPED LENGHT – ENTWICKELTE LÄNGE – DESARROLLO DE LA CURVA<br>– LUNGHEZZA SVILUPPATA |   |   |   |   |

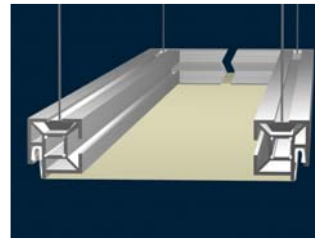

|          | DENOMINATION<br>DESCRIPTION<br>BESCHREIBUNG<br>DESCRIPCION<br>DESCRIZIONE                             | SENS<br>DIRECTION OF RADII<br>RICHTUNG - SENTIDO - SENSO |  | SCHEMA<br>VIEW - ZEICHNUNG - ESQUEMA<br>SCHEMA | R MINI (mm)<br>MINIMUM RADIUS<br>MINIMALER RADIUS<br>RADIO MINIMO<br>RAGGIO MINIMO |
|----------|-------------------------------------------------------------------------------------------------------|----------------------------------------------------------|--|------------------------------------------------|------------------------------------------------------------------------------------|
|          |                                                                                                       |                                                          |  |                                                |                                                                                    |
| <b>A</b> | <b>Plat concave</b><br>Concave vertical plane<br>Konkav Rundung<br>Plano concavo<br>Piano concavo     |                                                          |  |                                                | 400                                                                                |
| <b>B</b> | <b>Plat convexe</b><br>Convex vertical plane<br>Konvex Rundung<br>Plano convexo<br>Piano convesso     |                                                          |  |                                                | 300                                                                                |
| <b>C</b> | <b>Chant concave</b><br>Concave horizontal plane<br>Konkav Rundung<br>Canto concavo<br>Taglio concavo |                                                          |  |                                                | 400                                                                                |
| <b>D</b> | <b>Chant convexe</b><br>Convex horizontal plane<br>Konkav Rundung<br>Canto convexo<br>Taglio convesso |                                                          |  |                                                | 450                                                                                |



**N° CLIENT :**  
Customer – Kunde – Cliente – Cliente

**COMMANDE du / /**  
Order of – Bestellung Datum – Pedido del – Ordine del

| CINTRAGE<br>BENDING – BIEGUNGS – CURVATURA – CALANDRATURA                                                        | A | B | C | D |
|------------------------------------------------------------------------------------------------------------------|---|---|---|---|
| QUANTITE<br>QUANTITY – MENGE – CANTIDAD – QUANTITA                                                               |   |   |   |   |
| RAYON (mm)<br>RADIUS – RADIUS – RADIO – RAGGIO                                                                   |   |   |   |   |
| LONGUEUR DEVELOPPE (mm)<br>DEVELOPPED LENGHT – ENTWICKELTE LÄNGE – DESARROLLO DE LA CURVA – LUNGHEZZA SVILUPPATA |   |   |   |   |



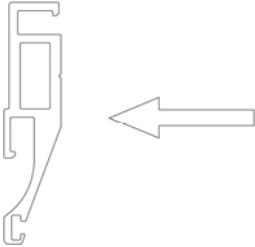

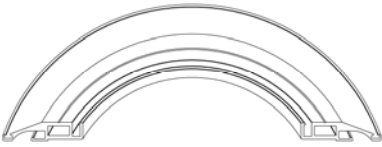
|          | DENOMINATION<br>DESCRIPTION<br>BESCHREIBUNG<br>DESCRIPCION<br>DESCRIZIONE                                                | SENS<br>DIRECTION OF RADII<br>RICHTUNG - SENTIDO - SENSO                            | SCHEMA<br>VIEW - ZEICHNUNG - ESQUEMA<br>SCHEMA                                       | R MINI (mm)<br>MINIMUM RADIUS<br>MINIMALER RADIUS<br>RADIO MINIMO<br>RAGGIO MINIMO |
|----------|--------------------------------------------------------------------------------------------------------------------------|-------------------------------------------------------------------------------------|--------------------------------------------------------------------------------------|------------------------------------------------------------------------------------|
| <b>A</b> | <b>BSC 355/08 A</b><br><b>Plat concave</b><br>Concave vertical plane<br>Konkav Rundung<br>Plano concavo<br>Piano concavo |   |    | 400                                                                                |
| <b>B</b> | <b>Plat convexe</b><br>Convex vertical plane<br>Konvex Rundung<br>Plano convexo<br>Piano convesso                        | X                                                                                   | X                                                                                    | <b>Non cintrable</b><br><b>Unbendable</b><br><br><b>X</b>                          |
| <b>C</b> | <b>Chant concave</b><br>Concave horizontal plane<br>Konkav Rundung<br>Canto concavo<br>Taglio concavo                    |  |  | <b>Non cintrable</b><br><b>Unbendable</b><br><br><b>X</b>                          |

**N° CLIENT :**

Customer – Kunde – Cliente – Cliente

**COMMANDE du** / /

Order of – Bestellung Datum – Pedido del – Ordine del

| CINTRAGE<br>BENDING – BIEGUNGS – CURVATURA – CALANDRATURA                                                        | A | B | C | D |
|------------------------------------------------------------------------------------------------------------------|---|---|---|---|
| QUANTITE<br>QUANTITY – MENGE – CANTIDAD – QUANTITA                                                               |   |   |   |   |
| RAYON (mm)<br>RADIUS – RADIUS – RADIO – RAGGIO                                                                   |   |   |   |   |
| LONGUEUR DEVELOPPE (mm)<br>DEVELOPPED LENGHT – ENTWICKELTE LÄNGE – DESARROLLO DE LA CURVA – LUNGHEZZA SVILUPPATA |   |   |   |   |



Catégorie **Lisse Star**

Category – Kategorie – Categoria – Categoria

 Référence **BSC 355/10**

Reference – Referenz – Seferencia – Riferimento

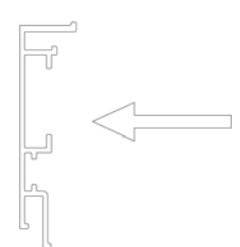
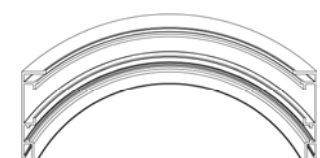
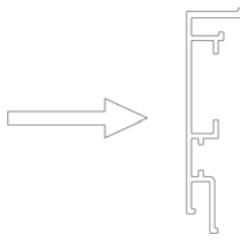
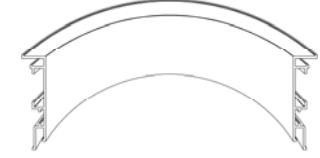

|          | DENOMINATION<br>DESCRIPTION<br>BESCHREIBUNG<br>DESCRIPCION<br>DESCRIZIONE                             | SENS<br>DIRECTION OF RADII<br>RICHTUNG - SENTIDO - SENSO                            | SCHEMA<br>VIEW - ZEICHNUNG - ESQUEMA<br>SCHEMA                                      | R MINI (mm)<br>MINIMUM RADIUS<br>MINIMALER RADIUS<br>RADIO MINIMO<br>RAGGIO MINIMO |
|----------|-------------------------------------------------------------------------------------------------------|-------------------------------------------------------------------------------------|-------------------------------------------------------------------------------------|------------------------------------------------------------------------------------|
| <b>A</b> | <b>Plat concave</b><br>Concave vertical plane<br>Konkav Rundung<br>Plano concavo<br>Piano concavo     |    |   | 300                                                                                |
| <b>B</b> | <b>Plat convexe</b><br>Convex vertical plane<br>Konvex Rundung<br>Plano convexo<br>Piano convesso     |   |  | 250                                                                                |
| <b>C</b> | <b>Chant concave</b><br>Concave horizontal plane<br>Konkav Rundung<br>Canto concavo<br>Taglio concavo |  |                                                                                     | <b>Non cintrable</b><br><b>Unbendable</b><br><br><b>X</b>                          |
| <b>D</b> | <b>Chant convexe</b><br>Convex horizontal plane<br>Konkav Rundung<br>Canto convexo<br>Taglio convesso |  |                                                                                     | <b>Non cintrable</b><br><b>Unbendable</b><br><br><b>X</b>                          |

 N° CLIENT :  
Customer – Kunde – Cliente – Cliente

 COMMANDE du / /  
Order of – Bestellung Datum – Pedido del – Ordine del

| CINTRAGE<br>BENDING – BIEGUNGS – CURVATURA – CALANDRATURA                                                        | A | B | C | D |
|------------------------------------------------------------------------------------------------------------------|---|---|---|---|
| QUANTITE<br>QUANTITY – MENGE – CANTIDAD – QUANTITA                                                               |   |   |   |   |
| RAYON (mm)<br>RADIUS – RADIUS – RADIO – RAGGIO                                                                   |   |   |   |   |
| LONGUEUR DEVELOPPE (mm)<br>DEVELOPPED LENGHT – ENTWICKELTE LÄNGE – DESARROLLO DE LA CURVA – LUNGHEZZA SVILUPPATA |   |   |   |   |







|          | DENOMINATION<br>DESCRIPTION<br>BESCHREIBUNG<br>DESCRIPCION<br>DESCRIZIONE                             | SENS<br>DIRECTION OF RADII<br>RICHTUNG - SENTIDO - SENSO | SCHEMA<br>VIEW - ZEICHNUNG - ESQUEMA<br>SCHEMA | R MINI (mm)<br>MINIMUM RADIUS<br>MINIMALER RADIUS<br>RADIO MINIMO<br>RAGGIO MINIMO |
|----------|-------------------------------------------------------------------------------------------------------|----------------------------------------------------------|------------------------------------------------|------------------------------------------------------------------------------------|
| <b>A</b> | <b>Plat concave</b><br>Concave vertical plane<br>Konkav Rundung<br>Plano concavo<br>Piano concavo     |                                                          |                                                | Entaillé 300<br>Sablé 500                                                          |
| <b>B</b> | <b>Plat convexe</b><br>Convex vertical plane<br>Konvex Rundung<br>Plano convexo<br>Piano convesso     |                                                          |                                                | Entaillé 300                                                                       |
| <b>C</b> | <b>Chant concave</b><br>Concave horizontal plane<br>Konkav Rundung<br>Canto concavo<br>Taglio concavo |                                                          |                                                | <b>Non cintrable<br/>Unbendable</b><br><br><b>X</b>                                |
| <b>D</b> | <b>Chant convexe</b><br>Convex horizontal plane<br>Konkav Rundung<br>Canto convexo<br>Taglio convesso |                                                          |                                                | <b>Non cintrable<br/>Unbendable</b><br><br><b>X</b>                                |

**N° CLIENT :**  
Customer – Kunde – Cliente – Cliente

**COMMANDE du / /**  
Order of – Bestellung Datum – Pedido del – Ordine del

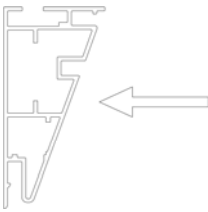
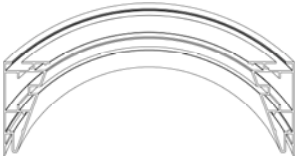
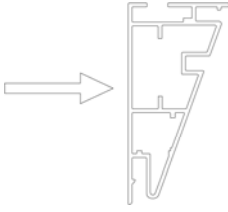
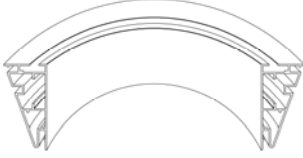
| CINTRAGE<br>BENDING – BIEGUNGS – CURVATURA – CALANDRATURA                                                        | A | B | C | D |
|------------------------------------------------------------------------------------------------------------------|---|---|---|---|
| QUANTITE<br>QUANTITY – MENGE – CANTIDAD – QUANTITA                                                               |   |   |   |   |
| RAYON (mm)<br>RADIUS – RADIUS – RADIO – RAGGIO                                                                   |   |   |   |   |
| LONGUEUR DEVELOPPE (mm)<br>DEVELOPPED LENGHT – ENTWICKELTE LÄNGE – DESARROLLO DE LA CURVA – LUNGHEZZA SVILUPPATA |   |   |   |   |



|          | DENOMINATION<br>DESCRIPTION<br>BESCHREIBUNG<br>DESCRIPCION<br>DESCRIZIONE                             | SENS<br>DIRECTION OF RADII<br>RICHTUNG - SENTIDO - SENSO                            | SCHEMA<br>VIEW - ZEICHNUNG - ESQUEMA<br>SCHEMA                                       | R MINI (mm)                                                         |
|----------|-------------------------------------------------------------------------------------------------------|-------------------------------------------------------------------------------------|--------------------------------------------------------------------------------------|---------------------------------------------------------------------|
|          |                                                                                                       |                                                                                     |                                                                                      | MINIMUM RADIUS<br>MINIMALER RADIUS<br>RADIO MINIMO<br>RAGGIO MINIMO |
| <b>A</b> | <b>Plat concave</b><br>Concave vertical plane<br>Konkav Rundung<br>Plano concavo<br>Piano concavo     |    |    | 5 000 non entaillé<br>Entaillé 300                                  |
| <b>B</b> | <b>Plat convexe</b><br>Convex vertical plane<br>Konvex Rundung<br>Plano convexo<br>Piano convesso     |   |   | 5 000 non entaillé<br>Entaillé 300                                  |
| <b>C</b> | <b>Chant concave</b><br>Concave horizontal plane<br>Konkav Rundung<br>Canto concavo<br>Taglio concavo |  |  | <b>Non cintrable</b><br><b>Unbendable</b><br><b>X</b>               |
| <b>D</b> | <b>Chant convexe</b><br>Convex horizontal plane<br>Konkav Rundung<br>Canto convexo<br>Taglio convesso |  |  | <b>Non cintrable</b><br><b>Unbendable</b><br><b>X</b>               |

**N° CLIENT :**  
Customer – Kunde – Cliente – Cliente

**COMMANDE du / /**  
Order of – Bestellung Datum – Pedido del – Ordine del

| CINTRAGE<br>BENDING – BIEGUNGS – CURVATURA – CALANDRATURA                                                        | A | B | C | D |
|------------------------------------------------------------------------------------------------------------------|---|---|---|---|
| QUANTITE<br>QUANTITY – MENGE – CANTIDAD – QUANTITA                                                               |   |   |   |   |
| RAYON (mm)<br>RADIUS – RADIUS – RADIO – RAGGIO                                                                   |   |   |   |   |
| LONGUEUR DEVELOPPE (mm)<br>DEVELOPPED LENGHT – ENTWICKELTE LÄNGE – DESARROLLO DE LA CURVA – LUNGHEZZA SVILUPPATA |   |   |   |   |

Catégorie **Cadre modulaire**

Category – Kategorie – Categoria – Categoría

 Référence **BSC 355/25**

Reference – Referenz – Seferencia – Riferimento

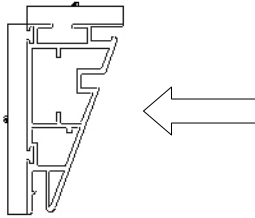
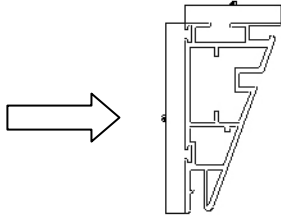

|          | DENOMINATION<br>DESCRIPTION<br>BESCHREIBUNG<br>DESCRIPCION<br>DESCRIZIONE                         | SENS<br>DIRECTION OF RADII<br>RICHTUNG - SENTIDO - SENSO                            | SCHEMA<br>VIEW - ZEICHNUNG - ESQUEMA<br>SCHEMA | R MINI (mm)<br>MINIMUM RADIUS<br>MINIMALER RADIUS<br>RADIO MINIMO<br>RAGGIO MINIMO |
|----------|---------------------------------------------------------------------------------------------------|-------------------------------------------------------------------------------------|------------------------------------------------|------------------------------------------------------------------------------------|
| <b>A</b> | <b>Plat concave</b><br>Concave vertical plane<br>Konkav Rundung<br>Plano concavo<br>Piano concavo |   |                                                | 5 000 non entaillé<br>Entaillé 300                                                 |
| <b>B</b> | <b>Plat convexe</b><br>Convex vertical plane<br>Konvex Rundung<br>Plano convexo<br>Piano convesso |  |                                                | 5 000 non entaillé<br>Entaillé 300                                                 |

**N° CLIENT :**

Customer – Kunde – Cliente – Cliente

**COMMANDE du / /**

Order of – Bestellung Datum – Pedido del – Ordine del

| CINTRAGE<br>BENDING – BIEGUNGS – CURVATURA – CALANDRATURA                                                        | A | B | C | D |
|------------------------------------------------------------------------------------------------------------------|---|---|---|---|
| QUANTITE<br>QUANTITY – MENGE – CANTIDAD – QUANTITA                                                               |   |   |   |   |
| RAYON (mm)<br>RADIUS – RADIUS – RADIO – RAGGIO                                                                   |   |   |   |   |
| LONGUEUR DEVELOPPE (mm)<br>DEVELOPPED LENGHT – ENTWICKELTE LÄNGE – DESARROLLO DE LA CURVA – LUNGHEZZA SVILUPPATA |   |   |   |   |



Catégorie **Cadre modulaire**

Category – Kategorie – Categoria – Categoria

 Référence **BSC 355/163**

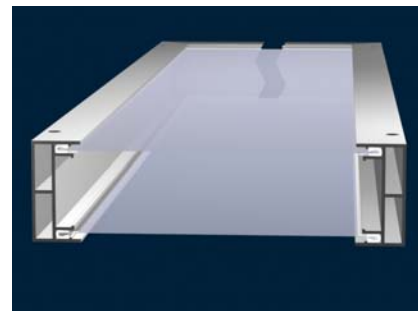
Reference – Referenz – Seferencia – Riferimento

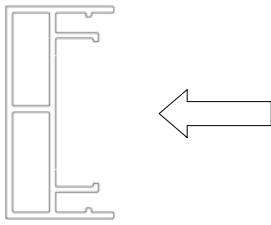

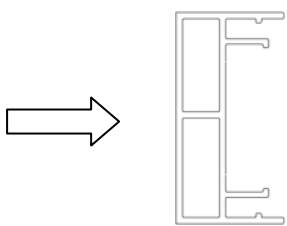
|          | DENOMINATION<br>DESCRIPTION<br>BESCHREIBUNG<br>DESCRIPCION<br>DESCRIZIONE                         | SENS<br>DIRECTION OF RADII<br>RICHTUNG - SENTIDO - SENSO                           | SCHEMA<br>VIEW - ZEICHNUNG - ESQUEMA<br>SCHEMA                                     | R MINI (mm)<br>MINIMUM RADIUS<br>MINIMALER RADIUS<br>RADIO MINIMO<br>RAGGIO MINIMO |
|----------|---------------------------------------------------------------------------------------------------|------------------------------------------------------------------------------------|------------------------------------------------------------------------------------|------------------------------------------------------------------------------------|
| <b>A</b> | <b>Plat concave</b><br>Concave vertical plane<br>Konkav Rundung<br>Plano concavo<br>Piano concavo |   |  | 500                                                                                |
| <b>B</b> | <b>Plat convexe</b><br>Convex vertical plane<br>Konvex Rundung<br>Plano convexo<br>Piano convesso |  |                                                                                    | 300                                                                                |

**N° CLIENT :**

Customer – Kunde – Cliente – Cliente

**COMMANDE du** / /

Order of – Bestellung Datum – Pedido del – Ordine del

| CINTRAGE<br>BENDING – BIEGUNGS – CURVATURA – CALANDRATURA                                                        | A | B | C | D |
|------------------------------------------------------------------------------------------------------------------|---|---|---|---|
| QUANTITE<br>QUANTITY – MENGE – CANTIDAD – QUANTITA                                                               |   |   |   |   |
| RAYON (mm)<br>RADIUS – RADIUS – RADIO – RAGGIO                                                                   |   |   |   |   |
| LONGUEUR DEVELOPPE (mm)<br>DEVELOPPED LENGHT – ENTWICKELTE LÄNGE – DESARROLLO DE LA CURVA – LUNGHEZZA SVILUPPATA |   |   |   |   |





Catégorie **Lisse cintrée**

Category – Kategorie – Categoria – Categoría

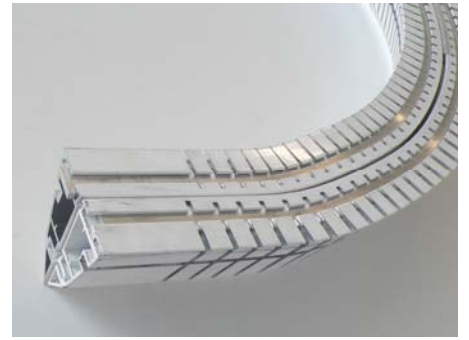
 Référence **BSC 355/35**

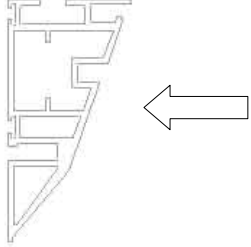
Reference – Referenz – Seferencia – Riferimento

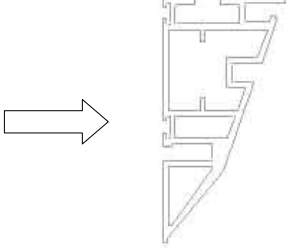

|          | DENOMINATION<br>DESCRIPTION<br>BESCHREIBUNG<br>DESCRIPCION<br>DESCRIZIONE                             | SENS<br>DIRECTION OF RADII<br>RICHTUNG - SENTIDO - SENSO                           | SCHEMA<br>VIEW - ZEICHNUNG - ESQUEMA<br>SCHEMA                                      | R MINI (mm)<br>MINIMUM RADIUS<br>MINIMALER RADIUS<br>RADIO MINIMO<br>RAGGIO MINIMO |
|----------|-------------------------------------------------------------------------------------------------------|------------------------------------------------------------------------------------|-------------------------------------------------------------------------------------|------------------------------------------------------------------------------------|
| <b>A</b> | <b>Plat concave</b><br>Concave vertical plane<br>Konkav Rundung<br>Plano concavo<br>Piano concavo     |   |   | 5 000 non entaillé<br>Entaillé 300                                                 |
| <b>B</b> | <b>Plat convexe</b><br>Convex vertical plane<br>Konvex Rundung<br>Plano convexo<br>Piano convesso     |  |  | 5 000 non entaillé<br>Entaillé 300                                                 |
| <b>C</b> | <b>Chant concave</b><br>Concave horizontal plane<br>Konkav Rundung<br>Canto concavo<br>Taglio concavo |                                                                                    |                                                                                     | <b>Non cintrable</b><br><b>Unbendable</b><br><br><b>X</b>                          |
| <b>D</b> | <b>Chant convexe</b><br>Convex horizontal plane<br>Konkav Rundung<br>Canto convexo<br>Taglio convesso |                                                                                    |                                                                                     | <b>Non cintrable</b><br><b>Unbendable</b><br><br><b>X</b>                          |

 N° CLIENT :  
Customer – Kunde – Cliente – Cliente

 COMMANDE du / /  
Order of – Bestellung Datum – Pedido del – Ordine del

| CINTRAGE<br>BENDING – BIEGUNGS – CURVATURA – CALANDRATURA                                                           | A | B | C | D |
|---------------------------------------------------------------------------------------------------------------------|---|---|---|---|
| QUANTITE<br>QUANTITY – MENGE – CANTIDAD – QUANTITA                                                                  |   |   |   |   |
| RAYON (mm)<br>RADIUS – RADIUS – RADIO – RAGGIO                                                                      |   |   |   |   |
| LONGUEUR DEVELOPPE (mm)<br>DEVELOPPED LENGHT – ENTWICKELTE LÄNGE – DESARROLLO<br>DE LA CURVA – LUNGHEZZA SVILUPPATA |   |   |   |   |